

Class 200 • Union Bonnet • Brz. Disc • Regrinding Seat • Thrd.

Globe Valve Figure B-37

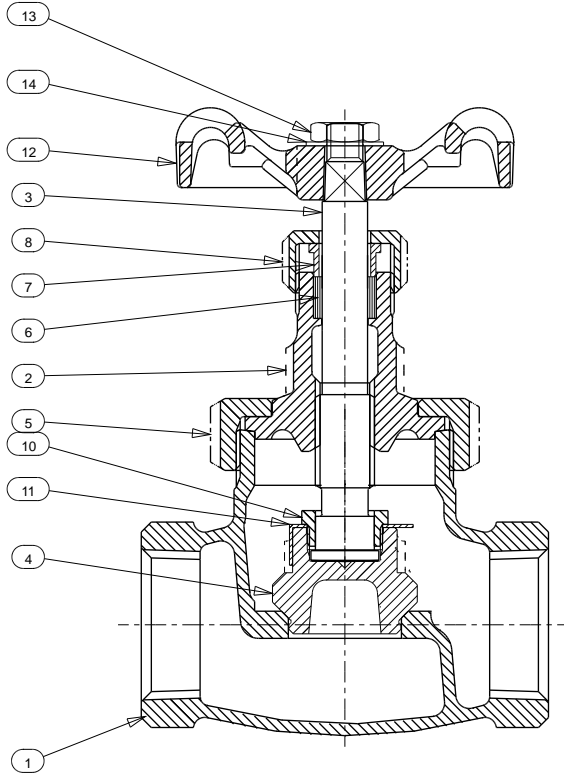

Materials of Construction

No.	Description	Material	ASTM Spec.
1	Body	Bronze	B-61 C92200
2	Bonnet	Bronze	B-61 C92200
3	Stem	Copper Silicon Bronze	B-371 C69400
4	Disc	Bronze	B-61 C92200
5	Union Ring	Bronze	B-62 C83600
6	Packing	Graphite (Asbestos Free)	
7	Gland	Brass	BSEN12164 CW614N
8	Packing Nut	(1/4" - 1 1/4") Brass	BSEN12164 CW614N
		(1 1/2" - 2") Bronze	B-62 C83600
10	Disc Stem Ring	Copper Silicon Bronze	B-371 C69400
11	Lock Washer	Brass	BSEN1652 CW507L
12	Handwheel	Malleable Iron	A-197 F22000
13	Handwheel Nut	Brass	BSEN12164 CW614N
14	ID Plate	Aluminum	

NOTE:

The addition of the letter "K" at the end of the figure number designates valves assembled & tested in the USA. Materials of Construction & Dimensions are the same.

Industry Standards

Complies with MSS SP-80 Type 1

See Page 6 for Pressure-Temperature Ratings

Dimensions and Weights

Inches (millimeters) - Pounds (kilograms)

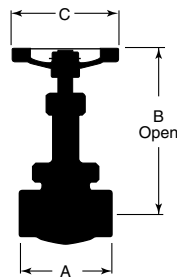

Valve Size	Dimensions			Wt.
	B	C	A	
1/4	4.80	2.05	2.05	1.24
	(122)	(52)	(52)	(0.56)
3/8	4.80	2.05	2.05	1.21
	(122)	(52)	(52)	(0.55)
1/2	5.51	2.56	2.44	1.76
	(140)	(65)	(62)	(0.80)
3/4	5.98	2.76	2.91	2.73
	(152)	(70)	(74)	(1.24)
1	6.73	3.07	3.54	4.01
	(171)	(78)	(90)	(1.82)
1 1/4	7.60	3.62	3.94	6.02
	(193)	(92)	(100)	(2.73)
1 1/2	8.66	4.06	4.53	8.34
	(220)	(103)	(115)	(3.78)
2	9.88	4.76	5.35	13.30
	(251)	(121)	(136)	(6.03)